

ChipTote Conveyor

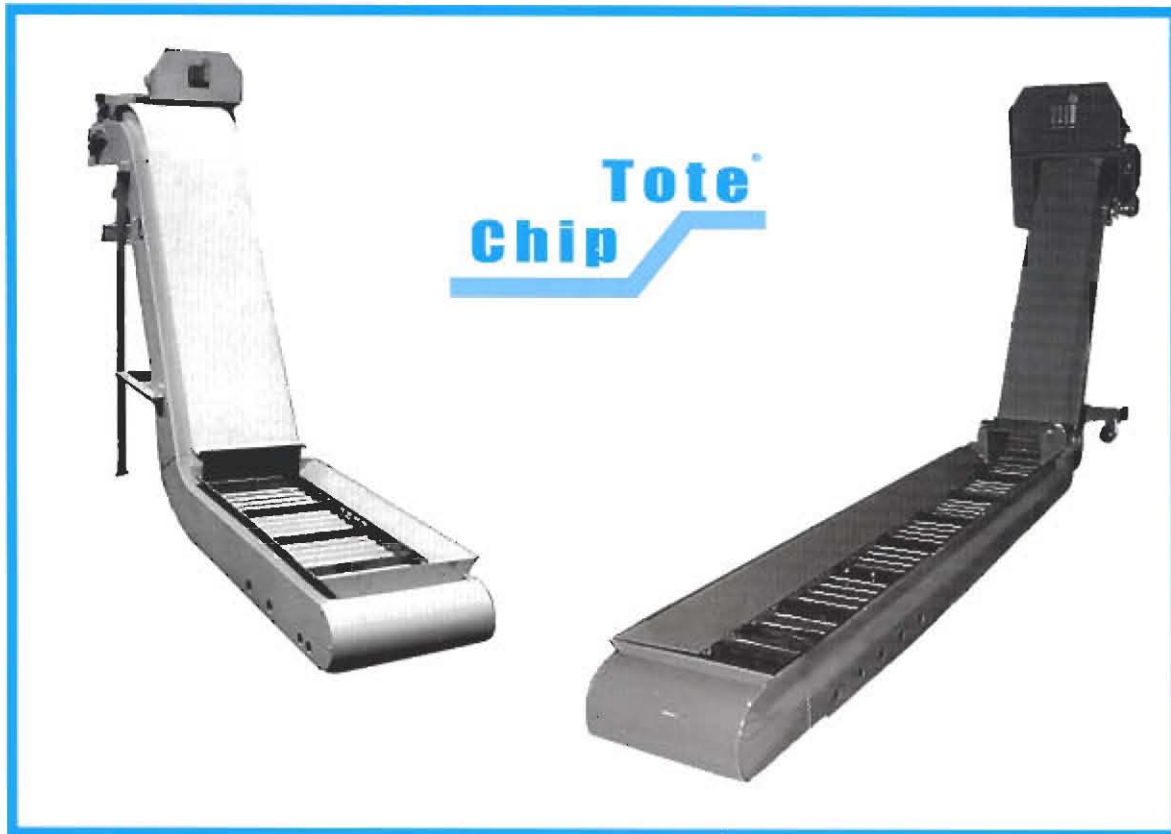

MAYFRAN CHIPTOTE

The Standard of the Industry

Mayfran ChipTote[®] conveyors keep chips, borings, turnings and swarf moving from high production machine tools. In addition to saving labor, you'll cut costly production downtime and help protect your machine tool from jam-ups.

Mayfran ChipTote conveyors are ideal for handling hot chips, wet chips, dry chips or borings, turnings and other swarf. They are also used in punching

and shearing scrap. Without top covers, they can be used for stamping scrap.

Custom-built to meet your specific requirements, ChipTotes are made from standard components for a wide range of machine tool applications.

A ChipTote conveyor coupled with Mayfran's application know-how, takes the worry out of chip handling. And, its rugged, proven design will give years of long service life.



P.O. Box 43038 Tel: (440) 461-4100
Cleveland, OH 44143-0038 Fax: (440) 461-0147
Internet: www.mayfran.com E-mail: Sales@mayfran.com

SPECIFICATIONS

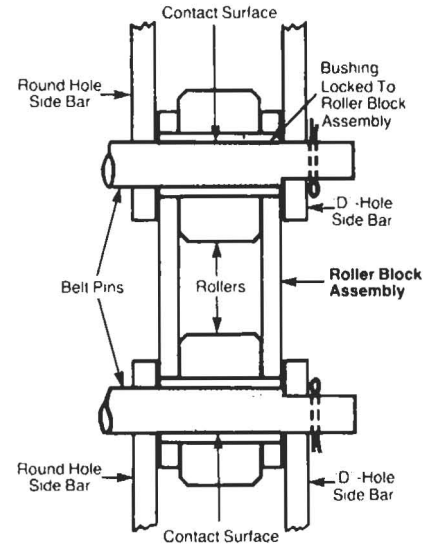
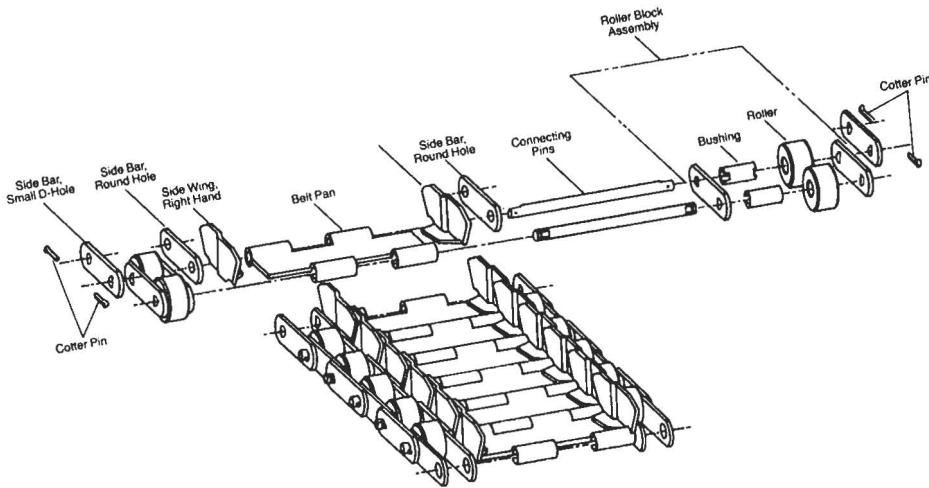

ChipTote Conveyors Have The Competitive Edge

Mayfran chain design has a large contact surface within the chain joint. This unique design distributes joint pressure evenly along a large section of the pin thus reducing premature wear.

As shown by the illustration, the ChipTote is designed with the chain separate from the belt. The side wings are welded to the belt pans providing a tight seal along each side of the belt to prevent material from lodging in the chain.

Wear is reduced with bushings locked into the roller-block assembly, minimizing relative motion between bushings and pins when the chain articulates.

Options to your ChipTote include top covers to compress balls of chips and turnings, a watertight bottom pan or coolant tank with or without pumps to recover fluids.

Belt options include perforated pans for extra drainage, dimpled pans for a non-stick surface or cleats to help elevate material at steeper angles. The drive can be side or top mounted. All drives include a safety clutch to protect from overloads.

Shaped to Meet Your Production Needs

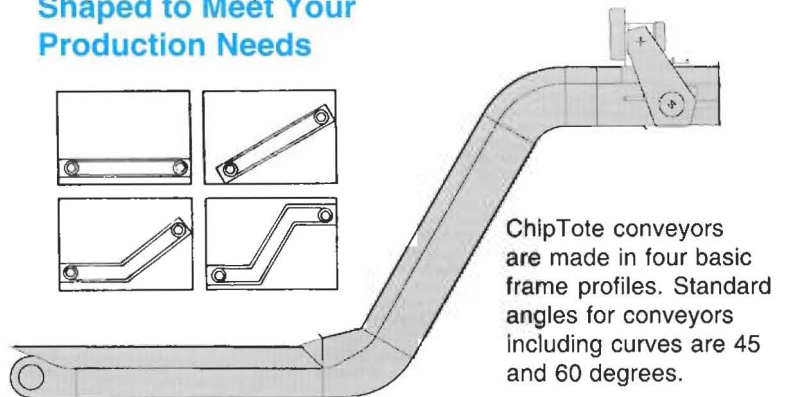

Mayfran International (USA) P.O. Box 43038 • 6650 Beta Drive Cleveland OH 44143 Tel: 440/461-4100 Fax: 440/461-5565

Mayfran International B.V. (Europe) PB 31032, Edisonstraat 7 • NL6370 AA Landgraaf, Netherlands Tel: 31-45-5329292 Fax: 31-45-5329300

Other Plants and Sales Offices:

Mayfran Canada Limited, 5955 Airport Road, Suite 300, Mississauga, Ontario L4V1 R9, Tel: 905/678-0018, Fax: 905/678-0019

Mayfran UK Ltd., Blundell House, Torrington Ave., Coventry CV49GO, UK, Tel: 441-203-422440 Fax: 441-203-422206

Mayfran GmbH, Roermonder Str. 594, 52072 Aachen, Germany, Tel: 49-241-938720, Fax: 49-241-175080

Mayfran France, Centre D'Affairs, 93153 Le Blanc Mesnil, P.O. Box 45 Paris-Nord France, Tel: 33-14-8657800, Fax: 33-14-8677629

Tsubakimoto Mayfran Inc., 5001, Ohno, Tsuchiyama-Cho, Kouga-Gun, Shiga 528-02, Japan, Tel: 81-7-486-7-1001, Fax: 81-7-486-7-1097

Miven Mayfran, P.O.Box 59 Karwar Rd., Hubli-580024, India, Tel: 91-836-303246, Fax: 91-836-303265

Korea Mayfran, 72-1, Onsoo-dong, Kuro-Ku Seoul, 152-120 Korea, Tel: 82-2-611-5886, Fax: 82-2-684-9166